

---

# 套标机说明书

## Description of the marking machine

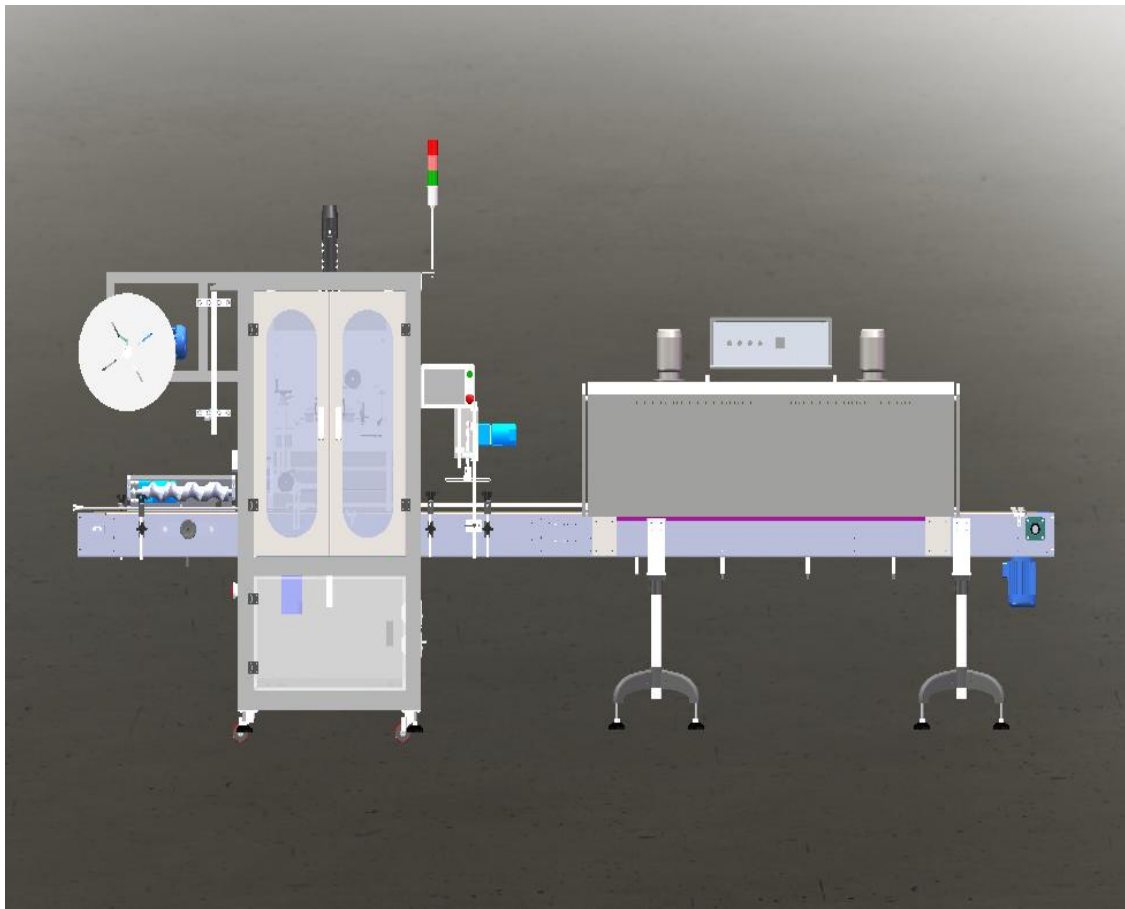

名称：电热收缩套标机

Name: electro thermal shrinkage sleeve marking machine

型号：DX-260

Model: DX - 260

---

# 目 录

第一章	前言.....	4
	Chapter 1 introduction.....	4
第二章	安全规范与守则.....	5
	Chapter ii safety regulations and rules.....	5
	2-1 安装安全要求.....	5
	2-1 installation safety requirements.....	5
	2-2 维护安全措施及维修安全措施.....	5
	2-2 maintenance safety measures and maintenance safety measures.....	5
	2-3 预检.....	7
	2-3 preview.....	7
	2-4 电器注意问题.....	8
	2-4 electrical attention problems.....	8
第三章	操作前准备.....	10
	<b>Chapter iii preparation before operation.....</b>	<b>10</b>
	3-1 操作注意事项.....	10
	3-1 operating instructions.....	10
	3-2 安装与清洁.....	10
	3-2 installation and cleaning.....	10
第四章	各部机构构成与功能.....	12
第五章	<b>Chapter iv structure and functions of the ministries.....</b>	<b>12</b>
	4-1 主机段输送线接口图.....	12
	Figure 4-1 interface diagram of conveying line of host section.....	12
	4-2 整机图示标识.....	13
	4-2 complete machine graphic logo.....	13
	4-3 各部件功能介绍.....	14
	4-3 function introduction of each component.....	14
第六章	标签膜料安装.....	17
	<b>Chapter vi installation of label film materials.....</b>	<b>17</b>
	5-1 图示.....	17
	5-1 graphic.....	17
	5-2 测试裁切.....	18
	5-2 test cutting.....	18

第七章	电眼架位置调整及设定.....	19
	<b>Chapter vii position adjustment and setting of electric eye frame.....</b>	<b>19</b>
	6-1 电眼架在卷标裁切时的位置调整.....	19
	6-1 position adjustment of the eyelet holder during marking cutting.....	19
	6-2 电眼感度的设定.....	19
	6-2 setting of inductance of electric eye.....	19
第八章	标签套标的定位侦测.....	21
	<b>Chapter viii. Positioning detection of label objects.....</b>	<b>21</b>
	7-1 标签套标原理.....	21
	7-1 label nesting principle.....	21
	7-2 图示电眼调整方位.....	21
	Figure 7-2 shows the electric eye adjusting its orientation.....	21
	7-3 照瓶电眼侦测说明.....	22
	7-3. Instructions for electric eye detection of light bottle.....	22
	7-4 调试要领.....	23
	7-4 debugging requirements.....	23
第九章	刀盘的拆卸、安装图示及说明.....	23
	<b>Chapter 9 disassembly, installation drawings and instructions of cutter head.....</b>	<b>23</b>
第十章	人机界面的操控说明.....	25
	<b>Chapter 10 operation instructions of man-machine interface.....</b>	<b>25</b>
	9-1 操作说明.....	25
	9-1 operating instructions.....	25
	9-2 画面解读.....	28
	9-2 screen interpretation.....	28
	9-3 常见异常及解除.....	36
	9-3 common exceptions and discharges.....	36
第十一章	其它组件的调整.....	38
	<b>Chapter 11 adjustment of other components.....</b>	<b>38</b>
	10-1 规格表.....	38
	<b>10-1 specification table.....</b>	<b>38</b>
第十二章	润滑与保养.....	39
	<b>Chapter xii lubrication and maintenance.....</b>	<b>39</b>
	11-1 每日例行检点事项.....	39
	11-1 daily routine inspection items.....	39

# 第一章 前 言

## Chapter 1 introduction

本套标机机体大量采用铝合金配合阳极处理及 304 不锈钢,使本机整体架构更坚固耐用,在机械的性能上更以模块化、人性化设计使得各项高速更容易,更换样式更为简便。在控制电路上使用人机接口控制,易学易懂,卓越电路设计更使得本机套标速度领先国际,由于本机完全采用新设计理念所研发,不仅减少很多机械上的调整,更提高了标签裁切的精度及生产速度,以下将就本机械操作方式进行详细说明。

This set of standard machine uses a large number of aluminium alloy with anode treatment and 304 stainless steel, so that the overall structure of the machine is more Strong and durable, more modular and humanized design in mechanical performance makes all kinds of high speed easier, easy to change the style. In the control circuit ,using man-machine interface control, easy to understand and more excellent . Circuit design makes the machine set of leading international standard speed, due to the machine design concept are fully developed, not only reduce a lot of mechanical adjustment, improve the accuracy of the label cutting and production speed, the following will discuss mechanical operating mode in detail.

## 第二章 安全规范与守则

### Chapter ii safety regulations and rules

#### 2-1 安装安全要求

##### 2-1 installation safety requirements

机台运抵现场，安装开机前，必须首先进行损伤检查。框架是否变形，电器柜是否受潮，尤其是所有组件是否有损伤痕迹（如碰撞痕迹）。如无法确定，请向制造单位核实机台是否损坏。一旦发现损坏，请即通知运输单位。

*When the machine arrives at the site, damage inspection must be carried out before installation and starting up. Whether the frame is deformed, whether the electrical cabinet is damp, especially whether all components have damage marks (such as collision marks). If not, please check with the manufacturer whether the machine is damaged. Please inform the transport unit as soon as damage is found.*

机台没有完全定位时，请勿拆除包装。本机台可以使用叉车搬运。请从机台的正前方底部插入进行搬运。请勿使用缆绳吊装！只有严格按照上述说明，才能保证安装安全。否则可能造成人员的伤害和机台的损坏。

*Do not remove the packing when the machine is not fully positioned. This machine can be carried by forklift. Please insert from the front of the platform at the bottom for handling. Do not use cable hoisting! Installation safety can only be guaranteed if the above instructions are followed strictly. Otherwise, it may cause damage to personnel and damage to the machine.*

请勿覆盖阻碍电器柜散热风机，确保散热正常，否则会使电器组件温度过高造成损坏和机台的工作不稳定。

*Please do not cover the fan that blocks the radiator of the electric cabinet to ensure the normal heat dissipation, otherwise it will cause damage to the electrical components and the work of the machine platform is unstable due to the high temperature.*

确认电源是否符合本机台的工作电源，电压不符会损坏电器组件。

*Confirm whether the power supply conforms to the working power supply of this machine, the voltage deviation will damage the electrical components.*

#### 2-2 维护安全措施及维修安全措施

##### 2-2 maintenance safety measures and maintenance safety measures

- ◆ 对电气和机械组件进行操作的工作人员必须经过培训，授权认可。
- ◆ *Personnel operating electrical and mechanical components must be trained and authorized.*
- ◆ 对机台的机械组件和电气进行维修的须是经过培训认可的工作人员。他必须熟悉机械安装和电气维修有一定经验的专业人员。
- ◆ *The maintenance of mechanical components and electrical equipment of the machine platform shall be carried out by trained and approved staff. He must be familiar with professionals with some experience in mechanical installation and electrical maintenance.*
- ◆ 定期进行机台检修维护，发现安全隐患立即排除，避免造成大的损失。
- ◆ *Carry out regular maintenance and repair of the machine platform, and eliminate the*

*safety hidden danger immediately to avoid causing great loss.*

- ◆ 决不允许在带电的机台上进行维修操作。
- ◆ *Maintenance operations are never allowed on live machines.*
- ◆ 只有把控制柜里的总回路断路器断开，切断机台总的供电以后，才能进行电气组件的维修操作。

Only when the main circuit breaker in the control cabinet is disconnected and the power supply of the machine station is cut off, can the maintenance of electrical components be carried out.

#### 注意 Note

- 即便机台电源开关断开，回路中仍有一部份电器组件带电。

Even if the power switch on the machine is disconnected, there is still a part of the electrical component in the circuit that is charged.

- 机台所有组件及传动系统至少一年检查一次。如果工作环境腐蚀严重，那么就要提高检查的频率。

**Check all components and drive systems at least once a year. If the working environment is seriously corroded, the inspection frequency should be increased.**

#### 维修安全措施 maintenance safety measures

所有的安装部件必须由专人进行维护，以避免机台的损坏和人员的伤害。机台一旦发生故障必须立即进行维修处理。由经过授权的技术人员及时排除机台的故障。每次维修过后，必须检查机台的防护安全装置，方可启动运行。

*All installation parts must be maintained by a dedicated person to avoid damage to the machine stand and personal injury. The machine must be repaired immediately in case of failure. Timely troubleshooting of the machine by authorized technicians. After each repair, the protective safety device of the machine must be checked before starting operation.*

不要用电焊切割或火焰切割任何零组件，除非切割部位不会引起火灾及不损伤其它部件的情况下。

*Do not cut or flame any zero component unless the cutting part does not cause fire or damage to other components.*

必须为机台提供相应的保护措施。一旦有火情，可以拿到灭火器。

*The corresponding protection measures must be provided for the machine. In case of fire, get a fire extinguisher.*

- 不要攀爬机台，应使用安全的平台或搭脚手架。

**No climbing platform, use safe platform or scaffolding.**

- 当使用机械设备（起重机等等）来起吊或移动零部件时，即便部件是较轻的，使用这些设备也应小心，因为也存在滑落或失去平衡的危险。

**When using mechanical equipment (cranes, etc.) to lifting or moving parts, even if the component is lighter, the use of these devices should be careful, because there is also a slide or in danger of losing balance.**

- 如零部件损坏无法修理，应向制造单位索取（限保修期内），不得自行测绘制造，这样会造成配合不当而损坏其它零组件。
- **If parts and components are damaged and cannot be repaired, they shall be requested from the manufacturer (within the warranty period) and shall not be manufactured by surveying and mapping, which will result in improper cooperation and damage other components.**

## 2-3 预检 preview

### 设备进场的检验 **Inspection of equipment entering the site**

检查机台是否完好无损。如果发现损坏或包装不完整。请立即通知运输公司。请确认收到的机台是否与贵公司订购的相符，比较订购的型号与名牌是否一致。确认订购的现场安装所有附件已收到，完整并且未受损坏。

*Check whether the machine is in good condition. If found damaged or incomplete packing. Please inform the shipping company immediately.*

*Please confirm whether the received machine is consistent with the one you ordered, and compare the model you ordered with that of the famous brand.*

*Confirm that all accessories ordered for on-site installation have been received, complete and not damaged.*

搬运请务必参考 3 外形尺寸，安装间隙以确保所有的连接和维修操作都有足够的空间。

*Be sure to refer to figure 3 for handling and install clearance to ensure adequate space for all connections and maintenance operations.*

- 只允许从指定的地方用叉车搬运，严禁吊装。  
**Only forklifts are allowed to be carried from designated places. Lifting is strictly prohibited.**
- 现场有足够的载重量以安装机台，或者至少有适当的禁固措施。  
**There is sufficient weight on site to install the platform, or at least appropriate locking measures.**
- 机台左右侧必须有合适的空间以保持空气流动和电器组件散热通风。  
**The left and right sides of the machine must have suitable space to maintain air flow and heat dissipation and ventilation of electrical components.**
- 在机台的正确的安装位置上应有足够的支撑点。

**Sufficient support should be provided at the correct installation position of the machine.**

- **禁止推压、撬动机台控制柜。机台底框是唯一的承重部位。**

**It is forbidden to push or lever the control cabinet of the machine platform. The bottom frame of the machine is the only bearing part.**

## **2-4 电器注意问题**

### **2-4 electrical attention problems**

套标机标准运行环境如下述：

The standard operating environment of the marking machine is as follows:

- **环境温度：-10°C 至+40°C**

Low temperature: - 10 ° C to + 40 ° C

- **安装：室内**

Ending installation: indoor

- **电源频率：50±5 HZ**

Power frequency: 50 ± 5 HZ

- **电压：1Ø210-230VAC**

Voltage: 1 Ø 210-230 vac

- **功率：3KW**

Power: 3KW

### **--电气安全要求 electrical safety requirements**

只有经过专业考核的人员才允许操作使用电气组件。需特别指出的是在进行电控柜内任何操作之前所有连接至机台的电源须先切断。可以通过断开主回路断路器来切断主电源供电。

Only those who have been professionally assessed are allowed to operate electrical components. It should be noted in particular that before any operation is carried out in the electric control cabinet, all the power connected to the machine platform must be cut off first. The main power supply can be cut off by disconnecting the main circuit breaker.

- **触电危险：即使当主电源被切断或主回路断路器被断开，机台上的某些电器组件仍可能带电。**

**Danger of electric shock: even when the main power supply is cut off or the main circuit breaker is cut off, some electrical components on the machine stand may still be charged.**



- 灼伤危险：电流会导致电气组件暂时或长时间发热，所以当接触及动力线缆、控制电缆、电源缆、接线盒盖及电机外壳时务必小心。

**Burn hazard: electrical components may heat temporarily or for a long time due to the current, so be careful when contacting power line cables, control cables, power cables, junction box covers and motor enclosures.**

- 即使当机台关机，只要供电回路断路器闭合，动力线线电缆仍然带电。详情参考电器原理图。

**Even when the machine is shut down, the power line cable is still charged as long as the power circuit breaker is closed. Refer to electrical schematics for details.**

- 如要对电控柜进行清扫，应用吸尘器，不可用未经过滤的压缩空气直接清扫。压缩空气中的水，油污会造成电器线路短路及绝缘电阻降低。

**If you want to clean the electric control cabinet, apply the vacuum cleaner, do not use unfiltered compressed air to clean directly. Water in compressed air, oil pollution will cause electrical circuit short circuit and insulation resistance reduction.**

### 第三章 操作前准备

#### Chapter iii preparation before operation

##### 3-1 操作注意事项

##### 3-1 operating instructions

开机前检查各机构螺栓是否有松动。

Check whether the bolts of each mechanism are loose before starting up.

3-1-1 开机后先用手动键试运转各机构工作是否有异常，无异常后方可自动状态运转。

After starting the machine, first test whether there is any abnormality in the work of each mechanism with the manual key, and then operate automatically without any abnormality.

3-1-2 急停开关开启后切刀机构会自动搜寻原点，在开启前应确保中心导柱安装到位不松动，否则会损坏中心导柱和切刀。

After the emergency stop switch is opened, the cutting tool mechanism will automatically search the origin. Before opening, it should ensure that the central guide column is installed in place, otherwise it will damage the central guide column and cutting tool.

3-1-3 更换切刀刀片后应注意刀片是否过长，以免打坏切刀。

After replacing the cutter blade, pay attention to whether the blade is too long to break the cutter.

3-1-4 待机或正常运转时不可将手伸进切刀工作区。

Do not put your hand into the cutter working area when standby or normal operation.

3-1-5 刷下不开启手动送标无效。

**3-1-5 no manual bidding will be opened under brush.**

### 3-2 安装与清洁 installation and cleaning

主机台、输送机、收缩炉等必须调至一条直线，输送机中心与主机台之刀盘中心对齐，基准面调至水平。主机基础螺丝高速至确实支撑地面，不可有空隙。入电源之电压必须确实核对。主机定位志必须有足够空间，以便日后点检维修，环境湿度不可高于 45°C，避免部分市购组件故障。主机放置位置必须避开风扇或冷气吹风口直吹，流动的风将会影响标签套标。

*The main machine, conveyor, shrinkage furnace and so on must be adjusted to a straight line, the center of the conveyor should be aligned with the center of the cutter disc of the main machine platform, and the base level should be adjusted to the level. The base screw of the main machine is high-speed enough to support the ground without any space. The incoming voltage must be accurately checked. Host orientation volunteers must have enough space, so as to tally maintenance in the future, environment humidity is higher than that of 45 ° C, avoid part of the city to buy component failures. The position of the host must be kept away from the fan or the cool air blower.*

#### ● 开机流程

Terminal start up process

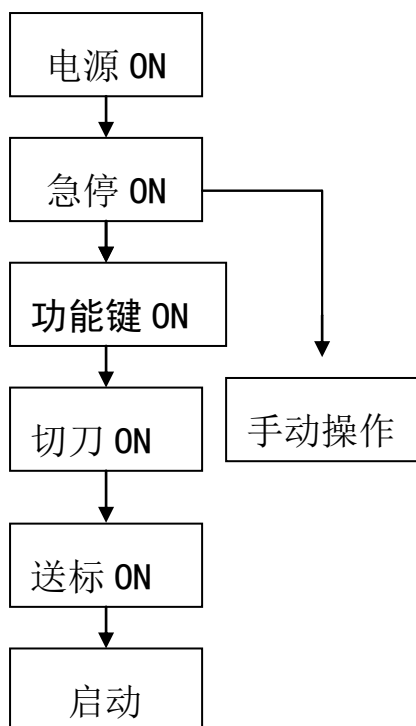

The power ON

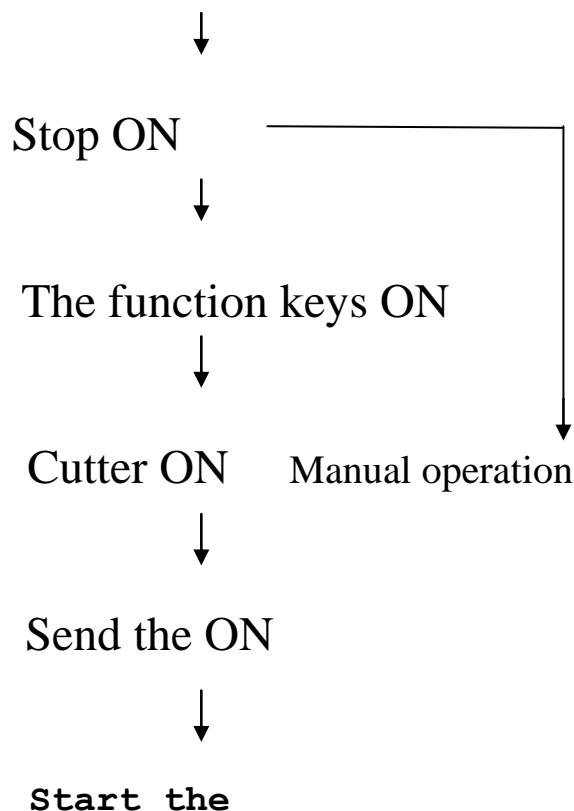

## -- 清洁

### - clean

去除运输及安装期间所滞留之灰尘，油渍等异物。机器传动部位之导杆、导轨、螺杆、齿轮滑座等滑动面，请用干净的擦拭清洁，重新上润滑油，必须注意：

皮带轮、皮带、橡胶轮及马达等电器零件不可上油。

Remove dust, oil stains and other foreign matter retained during transportation and installation. The guide bar, guide rail, screw rod, gear slide seat and other sliding surfaces of the machine drive should be cleaned with clean wipe and lubricated again.

The belt wheel, belt, rubber wheel and motor and other electrical parts must not be lubricated.

## 第四部分 各部机构构成与功能

### Chapter iv structure and functions of the ministries

#### 4-1 主机段输送线接口图

Figure 4-1 interface diagram of conveying line of host section

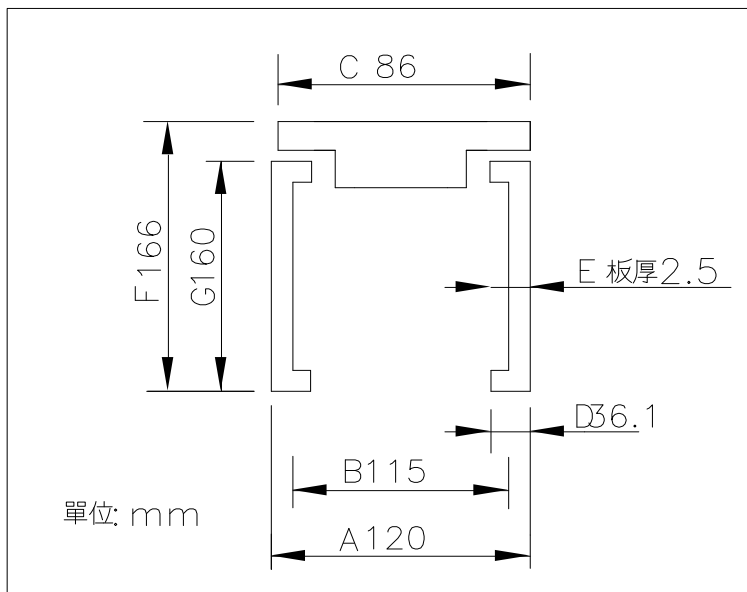

## 4-2 整机图示标识

### 4-2 complete machine graphic logo

-- 部件说明

-- component description

1、刀盘组

3、收缩炉

5、分瓶螺杆

7、三色警示灯

9、电眼架组

11、刷下组

13、输送带

15、送料架

2、机台组

4、驱动组

6、带瓶组

8、中心柱

10、毛刷组

12、料架组

14、照瓶电眼

16、人机界面

1. Cutter set

3. Shrinkage furnace

5. Bottle screw

7. Three-color warning lights

9. Electric eye frame group

11. Brush down group

13. Conveyor belt

15. Feed rack

2. Machine set

4. Drive group

6. Bottle group

8. Center column

10. Brush group

12. Material rack group

14. Light the battery

16. Man-machine interface

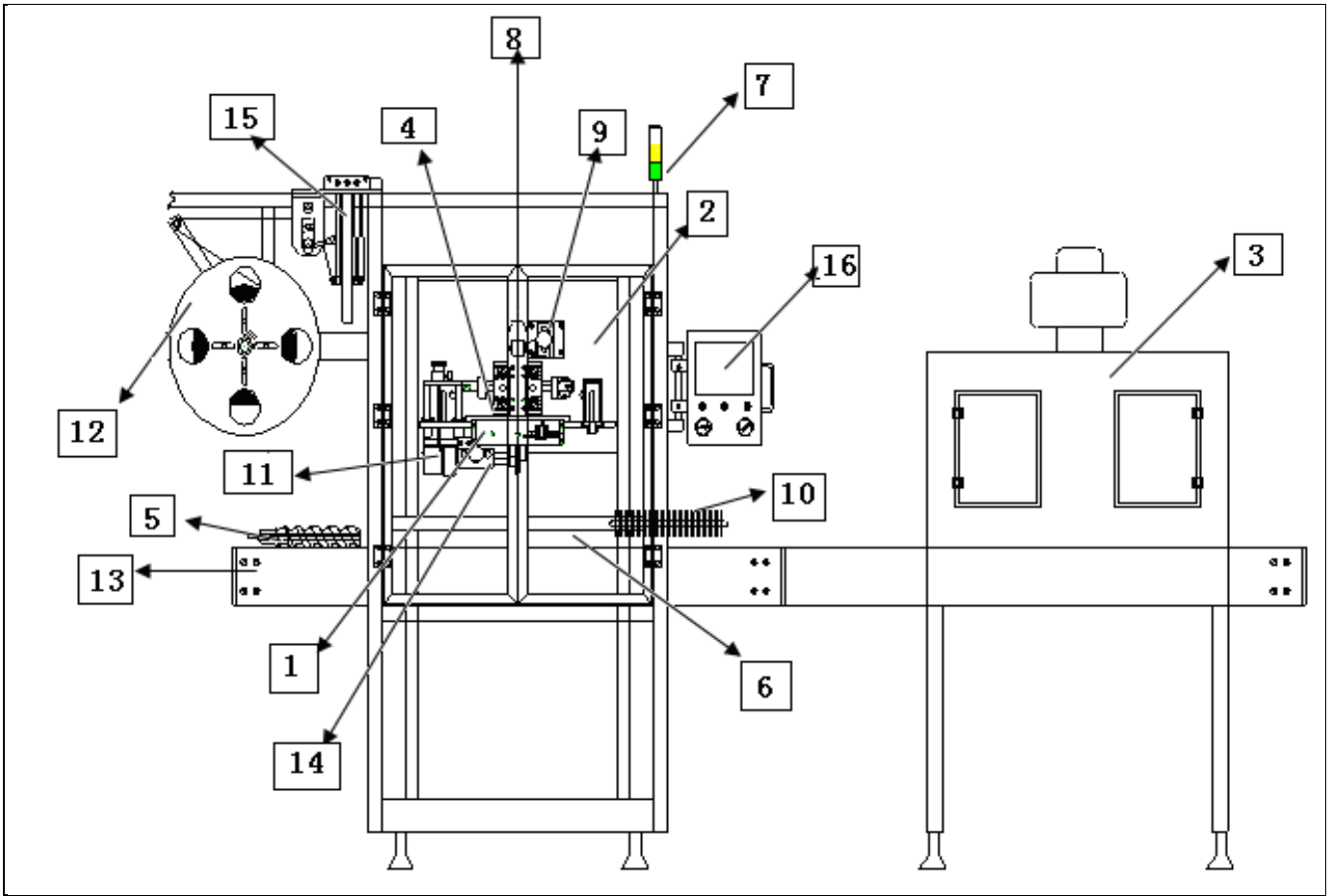

4-3 各部件功能介绍（此功能部件按照客户样品有所调整，应按照机型进行参照）

4-3 introduction to functions of each component (this functional component is adjusted according to customer samples and should be referred to according to the model)

● 刀盘组

**The knife dish group**

内置刀片，以行星配对方式及偏转曲轴式钢体架构，对收缩膜做裁切动作。

The inner blade cuts the shrink film by means of planetary alignment and deflection crankshaft steel structure.

● 机台架

**The machine frame**

全机采用铝合金配合阳极处理及 304 不锈钢材质，用于支撑主机及固定输送带。

The machine adopts aluminum alloy with anode treatment and 304 stainless steel material to support the main engine and fixed conveyor belt.

## ● 收缩炉(电热或蒸汽式)

### **Shrinkage furnace (electric or steam type)**

使用电热或蒸汽的热量将套入瓶子的标签收缩均匀附贴于瓶子之上。

Use the heat of electric or steam to shrink the label on the bottle evenly and attach it to the bottle.

## ● 驱动组

### **Driver group**

采用单组或双组机构式同步伺服马达控制，使收缩膜能固定尺寸输送。

A single or double set of synchronous servo motors are used to control the contraction film to be transported in a fixed size.

## ● 分瓶螺杆

### **Bottle screw**

将入料套入瓶子之上，利用螺杆定距输送，使瓶子有等距分开，以利于标签套入。

Insert the feeding material into the bottle, and use the screw to transport it at a fixed distance, so that the bottle is equidistant apart, so that the label can be put in.

## ● 带瓶组

### **A bottle of**

两侧同步转动，高低与夹瓶定位仅各一只手轮调整，目的使瓶子在输送时不摇晃及利于套标签高度的设定。

The two sides rotate synchronously, and only one hand wheel is used to adjust the height and positioning of the bottle holder. The purpose is to ensure that the bottle does not shake during conveying and to facilitate the setting of the height of the label.

## ● 三色警示灯

### **Three color warning light**

正常运转时为绿色警示灯，缺标签膜料时为黄色闪灯，主机不正常时闪红灯。

When running normally, it is green warning light, yellow flashing light when the label film material is missing, and red light when the host machine is abnormal.

## ● 中心柱

### **Low center column**

将标签膜料套入撑开，使膜料得以传送与裁切。

Insert the label film material into and open, so that the film material can be transmitted and cut.

## ● 电眼架组 **Magic eye frame group**

使用光线电眼传送信号，提供控制系统做定尺寸输送，电眼位置高低调整，确定刀盘内的刀片裁切位置。

Use the light electric eye to transmit the signal, provide the control system to do the size transmission, the position of the electric eye height adjustment, determine the cutting position of the blade in the cutter disc.

## ● 毛刷组 **Brush set**

利用橡胶将套入瓶子的标签刷打至定位。

Type the label brush into the bottle with rubber until it is positioned.

## ● 刷下组 **Under the brush set**

采用同步调整机构，将刷下两组传送轮调整至中心柱下方滚轮轻微接触，待标签通过时以较高转速将标签套入瓶子。

Using synchronous adjustment mechanism, the two sets of transmission wheels are adjusted to slightly touch the rollers under the center column. When the label passes through, the label is put into the bottle at a high speed.

## ● 料架组 **Material group**

标签膜料的固定纸环可由 5" 至 10" 调整后设定，出料由一组输送滚轮减速马达压送供料。

The fixed paper ring of the label film material can be set after adjustment from 5 "to 10", and the output of the material can be pressed by a set of roller speed motor to deliver the material.

## ● 输送带 **Conveyor belt**

使用变频器调整输送带速度，以适用于产能的速度相匹配。

Use a frequency converter to adjust the speed of the conveyor belt to match the speed applicable to the production capacity.

## ● 照瓶电眼 **According to bottle of magic eye**

监视瓶子至适当位置，输出讯号使主机自动套入卷标。

Monitor the bottle to the appropriate position and output the signal so that the main engine is automatically nested in the reel.

## ● 馈料组 Terms set

由控制标签送料张力的馈料箱与标签转向定位的电眼架组上方的馈料架所组成，用以传送标签膜料。

It is composed of a feed box controlling the feed tension of the label and a feed rack above the electric eye frame group which is used to transfer the label film.

## ● 人机界面 The man-machine interface

为本机控制中枢，各操作显示页区分为手动、自动、设定、异常显示等，另辅助几只旋钮，押钮用以操作套卷标作业。

As the control center of the machine, each operation display page is divided into manual, automatic, set, abnormal display, etc. Additionally, several knobs are assisted to operate the sleeve marking operation.

## 第五章 标签膜料的安装

### Chapter v installation of label film materials

#### 5-1 图示

#### 5-1 graphic

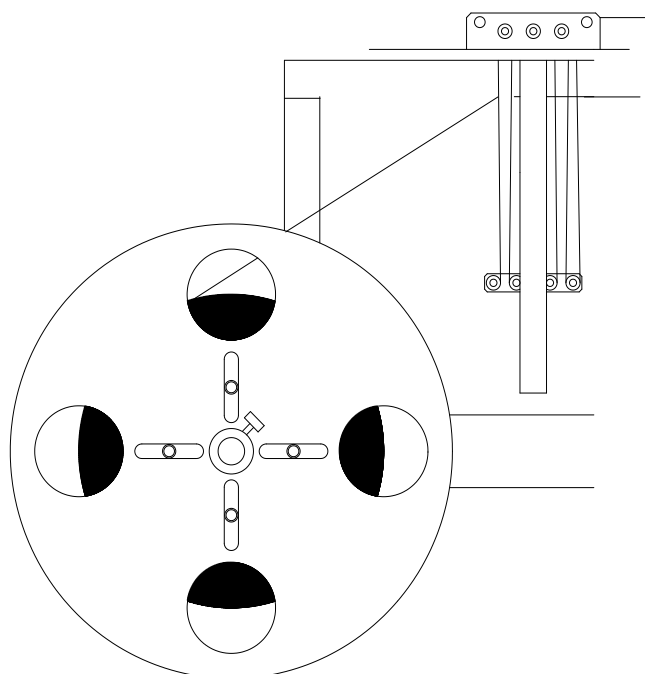

5-1-1 如图所示,将标签膜料放置料架上，套上膜料压板并稍施压后旋紧料架螺丝。

5-1-1 as shown in the figure, place the label film material on the material rack, cover the film material pressing plate and tighten the screw of the material rack after a little pressure.

5-1-2 依图示膜料方向出料，并且依顺时针方向将送料滚轮打开使膜料穿过滚轮间。

5-1-2 discharge in accordance with the direction of the film material shown in the figure, and open



the feed roller clockwise to let the film material pass through the roller.

5-1-3 将标签膜料依图穿绕各道轮间，再将膜料穿入中心柱尾翼。

5-1-3 pass the label film material around each wheel according to the figure, and then insert the film material into the tail of the central column.

5-1-4 膜料穿入中心柱前请将上驱动轮打开，后用左手托住中心柱底面并顶起使中心柱滚轮与主驱动轮部稍微脱离，右手将膜料穿过切刀位置，再将中心柱顺势用右手拉回固定。

Prior to the 5-1-4 film material through the center column on the driving wheel is opened, the left hand hold center column bottom and top up the center column of roller and the main driving wheel from a little, right hand will membrane material through the cutter location, then center conveniently back fixed with the right hand column.

5-1-5 中心柱移回原位后，再将上驱动轮夹回定位，稍接触即可，此时标签安装已经完成。

After the center column of 5-1-5 is moved back to its original position, the upper drive wheel will be clamped back for positioning. Just touch it slightly.

## 5-2 测试裁切

### 5-2 test cutting

在人机接口主页显示中按切标按钮后，选择送标进行裁切，反复试切至少五次，将不标准的标签膜料切除，注意最后应按启动键后才能进入自动模式页。

In man-machine interface according to the cutting of the home page display the button, select the standard for cutting, at least five times repeatedly, will not be the standard label membrane material removal, should pay attention to the last press the start key after page can enter into automatic mode.

## 电眼架位置的调整及设定

## Chapter 6 adjustment and setting of position of electric eye frame

### 6-1 电眼架在卷标裁切时的位置调整

#### 6-1 position adjustment of the eyelet holder during marking cutting

6-1-1 可向上或向下调整电眼架滑座高低的位置。

6-1-1 the position of the slider height of the electric eye frame can be adjusted up or down

6-1-2 当标签上方太长时，将电眼架滑座向上调整。

6-1-2 when the top of the label is too long, adjust the eyelet holder slider upward.

6-1-3 当标签下方太长时，将电眼架滑座向下调整，以上调整直到切至正确位置即可。

6-1-3 when the bottom of the label is too long, adjust the sliding seat of the electric eye frame downward, and the above adjustment can only be made until the correct position is cut.

### 6-2 电眼感度的设定（见附件）

#### 6-2 setting of inductance of electric eye (see attachment)

6-1-1 基于各种标签色泽、浓淡、膜料厚度不同，虽然机台在出厂安装后，已经由我司工程人员调试设定，但是在更换不同标签膜料时，可能会产生电眼感度对该标签套标

时造成影响，如感度太高或太低，导致生产时卷标刷下套入不正常，感度太高常会发生标签长度较短，感度太低则易发生一连串标签膜料向下拉之情形。当上述状况发生时，表示电眼感度必须作调整，以符合该种标签膜料的条件。

6-1-1 based on various label color, shading, thickness of the membrane material, while the machine is used in the factory after installation, have engineering personnel debugging set by us, but in replacing different labels membrane material, may produce magic eye sensitivity to the label of label, such as sensitivity is too high or too low, lead to production volume label under the brush set into the abnormal, high sensitivity often happen label length is shorter, the low sensitivity is prone to a series of label film material down. When the above situation occurs, it means that the inductance of the electric eye must be adjusted to meet the conditions of this kind of label film material.

6-1-2 调整感度时请先将标签拉至电眼附近，并确认印刷透明处在该位置，此时观察电眼感应器上红灯与绿灯是否为灯灭状态，如将标签上下移动仍不能使红灯熄灭时，此为透明感度弱，将标签透明段对准电眼，调整电眼上的感度钮，直到红绿灯刚灭位置后再往回调整至红灯亮。

6-1-2 please pull TAB to adjust the sensitivity near the electric eye, and confirm the printing transparent at the location, the red light and green light on the photoelectric sensor has been observed at this time was status lights are out, as will move up and down label is still not make the red light dies, this is a clear degree is weak, aim the label transparent section electric eye, adjust the sensitivity button on the electric eye, until the traffic lights just destroyed position back again after adjustment to the red light.

6-1-3 原则应调至红绿灯全亮，部份由于标签膜料上的印刷等透光度较强，可能造成电眼所侦测部位误判，导致标签下套不正常。

The principle of should be adjusted to all the traffic lights. In part, due to the high transmittance of printing and other materials on the label film, it may lead to misjudgment of the detected parts of the electric eye, which may lead to abnormal under the label cover.

6-1-4 倘若调整仍有不正常，请再重复以上步骤，并将感应器上的感度钮稍试调多或少些即可测试出电眼感度旋钮的恰当位置。

6-1-4 if the adjustment is still abnormal, repeat the above steps and test the appropriate position of the sensor knob by adjusting the sensor more or less.

标签套标的定位侦测 Chapter vii label mark locating detection

## 7-1 标签套标原理

### 7-1 label nesting principle

当输送带上有瓶子经过侦测瓶子电眼时，伺服控制的驱动组会自动一张标签，同时下刷料轮组会刷下一长标签，此标签就会套入瓶子上。若此时定位侦测电眼位置不正确时，就无法将标签顺利套入瓶子。

When there is a bottle on the conveyor belt passing through the detection of the bottle electric eye, the servo control drive group will automatically put a label, and the lower brush wheel group will brush a long label, which will be put on the bottle. If the position of the electric eye is not correct, the label cannot be put into the bottle successfully.

### 7-2 图示电眼调整方位

## Figure 7-2 shows the electric eye adjusting its orientation

7-2-1 依图示方向调整，若标签套入瓶内呈 A 状态时，请将电眼位置向 B 方向移动，倘若为 C 情况时，请将电眼位置由 C 向 B 方向移动，直到标签套入如 B 瓶正确为止。

The 7-2-1 adjustment according to graphic direction, if the label set in A state into the bottle, please move the magic eye location in the direction of B, if to C, please move the magic eye position from C to B direction, until label bottles right into such as B.

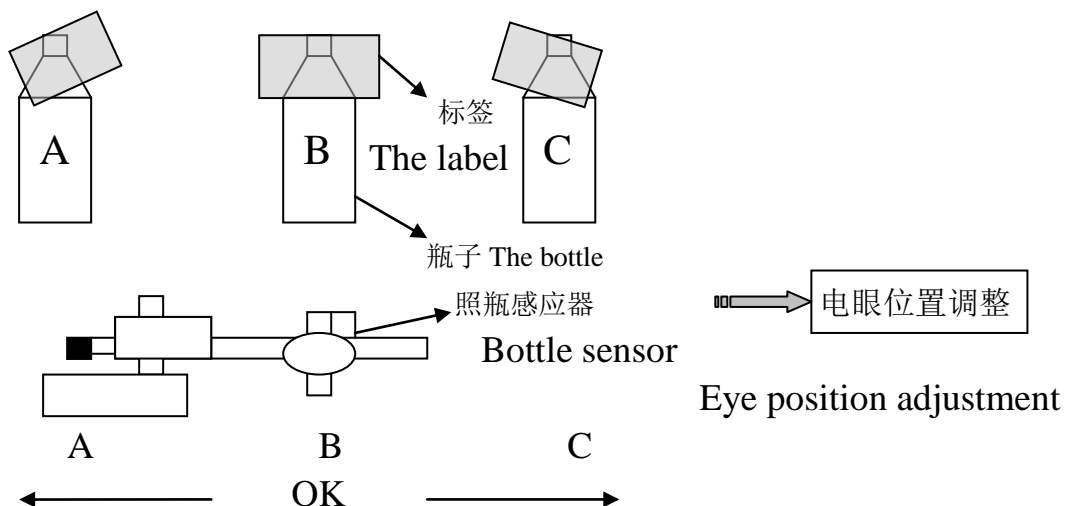

## 7-3 照瓶电眼侦测说明

### 7-3. Instructions for electric eye detection of light bottle

7-3-1 本电眼装置为反射型，主体为可移动架构，安装于导轨上，主体将投射光发射于被套标物上，再反射回主体接收，作为标签套入的信号传输。

7-3-1 this magic eye device for the reflective, subject to mobile architecture, installed on the guide rail, the body will project the light emission on the bedding bag to cluster, and then reflected back to the main body to receive, as the tag set into the signal transmission.

7-3-2 当无被套标物时，主体感应器上的灯号为 OFF 状态，此时若灯号为亮 ON 情况，请用小型一字起子调整该感度钮，直到确定感应器动作灯灭。

The 7-3-2 when no bedding bag label content, main body sensors ON the lights for the OFF state, at this time if the lights for the light ON, please use small screwdriver to adjust the sensitivity knob, a word until determine sensor lights went out.

7-3-3 当有被套标物时，投射光受到瓶子的反射，此时感应器上的灯号应为 ON 状态；若为 OFF 灯灭的情况时，则表示主体投射光太弱而无法反射，应调整感度钮，将感度调强至灯亮为止，

7-3-3 when there is a covered object, the projected light is reflected by the bottle. At this time, the light ON the sensor should be ON. If it is the case of OFF lamp, it means that the main body projection light is too weak to reflect. The sensitivity button

should be adjusted and the sensitivity should be adjusted until the light is on.

7-3-4 请反复试机调整直到确认感应器的感度适合为止。

7-3-4 please repeatedly test the machine and adjust it until it is confirmed that the sensor is suitable.

## 7-4 调试要领

### 7-4 debugging requirements

7-4-1 输送线、分瓶螺杆、带瓶定位皮带 3 组机构线速度调整不一致会造成标签无法套入或不稳定。

The speed adjustment of the three groups of mechanism line is inconsistent, which may cause the label to be unable to be inserted or unstable.

7-4-2 以下为瓶罐向前倾斜：原因 1.带瓶皮带过快。2.输送线过慢。

Reason: 1. The bottle belt is too fast. 2. The transmission line is too slow.

7-4-3 如果瓶罐向后倾斜：则与上面相反。

7-4-3 if the bottle is tilted backward: the opposite is true.

以下现象通过调整面板上旋钮即可达到一致

The following phenomena can be achieved by adjusting the knob on the panel

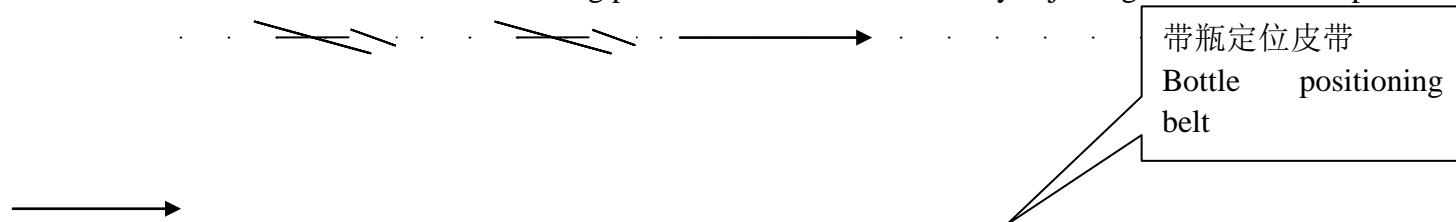

7-4-4 标签套不到位

7-4-4 label cover not in place

原因：1.毛刷未打到标签 2.带瓶皮带过高 3.下标不正 4. 7.1.1 和 7.1.2 也会造成。

Reason: 1. The brush did not hit the label 2. The bottle belt was too high 3.

## 第八章 刀盘的拆卸与安装

### Chapter viii disassembly and installation of knife plate

#### 8-1 图刀盘组机构平面图

#### Figure 8-1 schematic diagram of the mechanism of the tool set

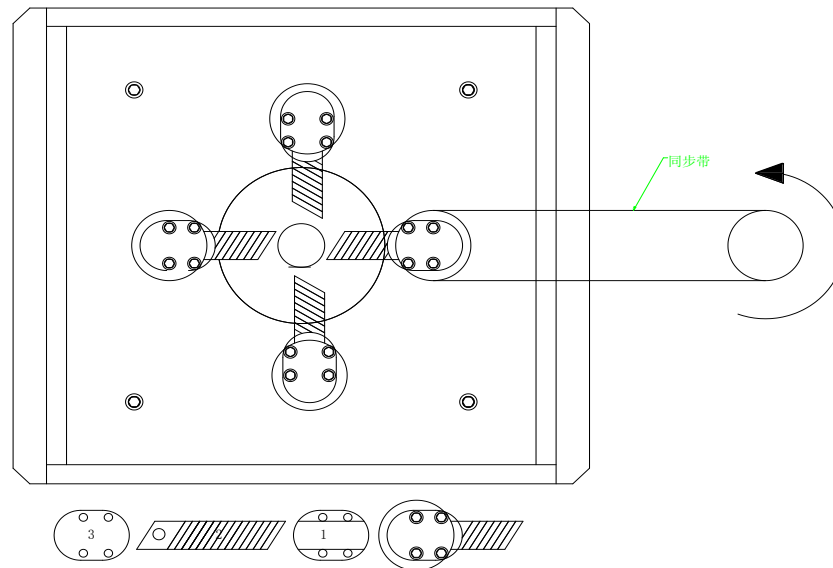

## 8-2 安装详细介绍

### 8-2 installation details

8-2-1 若需要更换刀片，请依图所示进行拆卸。

8-2-1 if the blade needs to be replaced, please disassemble as shown in the figure.

8-2-2 更换刀片时，请注意原旧刀片折断所留格数，也就是刀片长度，新刀片要比照旧刀片长度才可安装，否则裁切标签时可能会发生膜料未断，标签不能刷下的现象。

The 8-2-2 replacement blades, please note that the original old blade broken bars, which is the length of the blade, a new blade to blade length than those can only be installed, or cutting labels may occur when the membrane material is not broken, the label can't brush the phenomenon.

8-2-3 安装刀片时要注意：A 刀片是否有装入刀砧座的刀沟内。B 刀片长度确定后折断刀片时不得操作刀刃与刀片尖端部位。C 刀片安装时应按刀盘原安装的方向进行安装。

Note when installing the blade: whether the blade A is loaded into the groove of the anvil seat. B. When the blade length is determined and the blade is broken, the blade and tip of the blade shall not be operated. C. When installing the blade, it shall be installed according to the original installation direction of the cutter disc.

8-2-4 刀片安装后，在挂皮带时应注意皮带上所记标记，按标记挂好，避免卡标，方可运转正常。

After the 8-2-4 blade is installed, please pay attention to the mark on the belt when you hang the belt, and hang it according to the mark, so as to avoid the marking, and then the belt can operate normally.

8-2-5 拆装刀片时要注意安全避免被刀片割伤；使用工具拆卸时手部要离开刀片区域内，左手必须确认握住拉紧时规皮带后，再行拆装刀片压板螺丝，注意压板适度上紧即可，以避免压板变形。

8-2-5 when removing and installing the blade, pay attention to safety to avoid cutting by the blade;  
When using the tool to remove the hand to leave the blade area, left hand have to confirm, after holding on tight timing belt in dismantling any blade clamp screw, pay attention to the platen moderate tightening can, to avoid the pressure plate deformation.

8-2-6 倘若发现有各组刀片角度有不正常或异常、异音，请通知本公司服务检修。

8-2-6 if any abnormal or abnormal blade Angle or voice is found in each set of blades, please inform the company of service maintenance.

## 第九章 人机介面操控说明

### Manual interface control instructions

#### 9-1 操作说明

#### 9-1 operating instructions

本套标机操作装置为萤幕触控操作式人机介面为主，并加以数个外部辅助传统开关装置下方所构成，机器所有功能的选择状态、显示等讯息，均可藉由此一装置之各显示页所设计的功能达成，简明易懂，具有良好的亲和性。

This set of marking machine operation device for touch screen man-machine interface operation type is given priority to, and a number of external auxiliary below the traditional switch device, the machine all the features of the selection state, display and other information, all can borrow from each page shows the designed functions of a device, simplicity, has the good affinity.

9-1-1 开机：如上图开关流程与关机流程

9-1-1 start up: as shown above, switch flow and shutdown flow

9-1-2 各页功能说明：

9-1-2 function description of each page:

##### (一) 主功能选择表

##### (1) master function selection table

1、电源指示灯：机器正常运行状态下亮起绿灯。

1. Power indicator: the green light is turned on when the machine is running normally.

2、紧急停止：在非正常情况下所使用。

2. Emergency stop: used in abnormal situations.

**(二) 手动操作界面:**

**(ii) manual operation interface:**

- 1、放标电机：以控制送料滚轮动作。
  1. Marking release motor: to control the feed roller movement.
- 2、切刀点动：完成送料至套标的切断动作。
  2. Cutting tool spot movement: complete the cutting action of feeding material to the sleeve object.
- 3、分瓶电机：自动控制瓶子的进瓶间距。
  3. Bottle dividing motor: automatic control of bottle spacing.
- 4、标板电机升 / 降：由人机界面控制主机的升降，以达到瓶子套标的高度。
  4. Motor lift/fall of the standard plate: the main engine is controlled by the man-machine interface to reach the height of the bottle sleeve.

**(三) 自动模式：开启自动运行模式。**

**(3) automatic mode: open automatic operation mode.**

**(四) 参数设定:**

**(iv) parameter setting:**

- 1、产品计数量：计数量最大为：9999999。
  1. Product quantity: the maximum quantity: 9999999.
- 2、标签长度设定：在定长功能时，设定标签之长度。
  2. Label length setting: when the length setting function is used, the label length is set.

**9-1-3 辅助功能开关:**

**9-1-3 auxiliary function switch:**

**(一) 紧急停止：在异常时，紧急停止运行程序。**

**(1) emergency stop: in case of any abnormality, the operation procedure shall be stopped urgently.**

**(二) 速度调整钮：控制带瓶组送瓶的速度。**

**(2) speed adjustment button: control the speed of bottle delivery with bottle group.**

**(三) 分瓶螺杆：控制进瓶距离。**

**(3) separating screw: control the distance of bottle entry.**

(四) **热收缩炉开关**: 启动后使用之完成标签收缩动作。

(4) **heat shrinkable furnace switch**: it is used to complete label shrinkage after start-up.

(五) **警报解除**:

(5) **lifting of the alarm**:

9-1-4 警报状态讯息:

*9-1-4 alarm status message:*

本机器控制系统以三色灯号、界面屏幕文字显示两种方式组合而成的警报讯息。

*The machine control system displays the alarm information in two ways: three color lamp number and interface screen text.*

(五) **三色灯号**: 红、黄、绿三色灯由上而下排列在主机右后上方, 代表的状态意义如下面所述:

*(6) tri-colour lights: red, yellow and green lights are arranged from top to bottom on the upper right and the upper right of the host. The status meaning of the lights is as follows:*

1、红灯: 表示主机异常。

*1. Red light: the host is abnormal.*

2、黄灯: 表示黄灯常亮时, 为无异常, 待机状态。

*2. Yellow light: when the yellow light is always on, it is normal and standby.*

3、绿灯: 表示自动状态, 无异常。

*3. Green light: represents the automatic state, without any exception.*



## 9-2 画面解读

### 9-2 screen interpretation

#### 1, 自动画面



#### 1. Automatic screen



**启动**: 开启自动模式 (启动前需要把所有功能键开关按照所需要用到的功能将其打开) (功能键会和非标定制的不同)

Start: turn on automatic mode (all function key switches need to be turned on before starting) (function keys will be different from non-standard customization)

**停止**: 停止自动模式

Stop: stop automatic mode

**清 0**: 清除生产记录数据

Clear 0: clear production record data

**测标电眼/标签长度模式**: 设定标签长度 (备注: 在此输入数值后显示器会自动默认测标电眼模式, 如需使用长度模式可电机测标电眼模式自动切换成标签长度模式)

Mark magic eye/label length mode: set the label length (note: after this input numerical display will automatically default mark magic eye pattern, if you want to use the length of the model to motor test standard magic eye automatic switch to label the length of the pattern)

**生产数量**: 记录生产的数量 (有掉电保持功能)

Quantity of production: record the quantity of production (power off maintenance function)

**分瓶**: 分瓶螺杆电机开启/关闭

Separating cylinder: opening/closing of separating screw motor

**刷标**: 刷标电机开启/关闭

Brush marks; Brush motor on/off

**导瓶**: 导瓶电机开启/关闭

Guide cylinder: the motor of guide cylinder opens/closes

**压标**: 压标马达开启/关闭

Mark pressing: mark pressing motor on/off

**输送线**: 输送线马达开启/关闭

Transmission line: the transmission line motor is on/off

**套标**: 套标电机开启/关闭

Set mark: set mark motor on/off

**割刀**: 割刀电机开启/关闭

Cutter: the cutter motor is on/off

**送标**: 送标电机开启/关闭

Bid delivery: start/close of bid delivery motor

**风机**: 风机电机马达开启/关闭

Fan: fan motor motor start/close

**上升**: 机头上升。 （打开手动界面）

**Up: head up. (open the manual interface)**

**下降**: 机头下降。 （打开手动界面）

**Drop: head down. (open the manual interface)**

## 2, 手画面

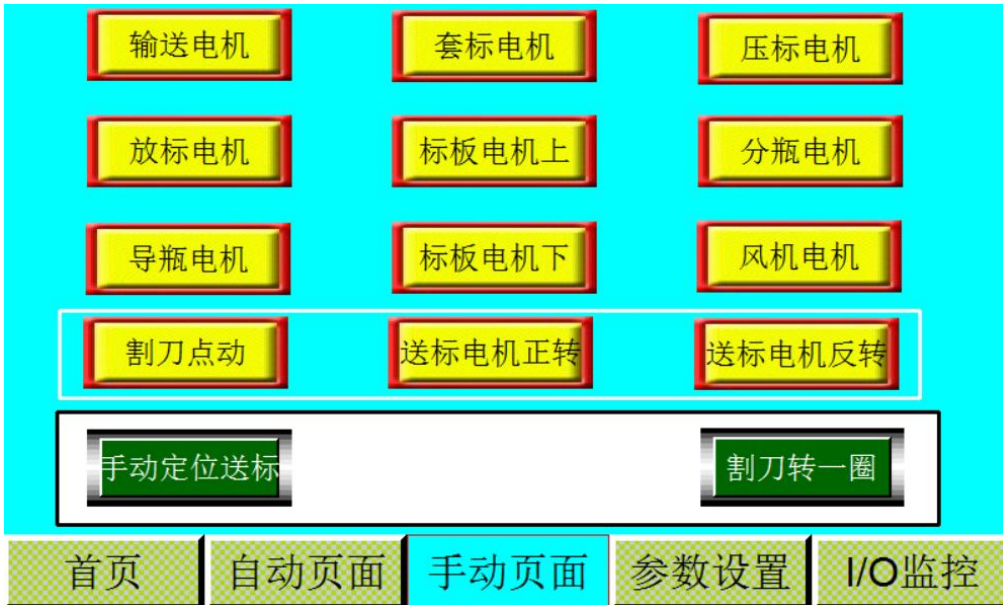

(手动: 点击按键则驱动电机, 松开电机则停止)

## 2. Manual screen

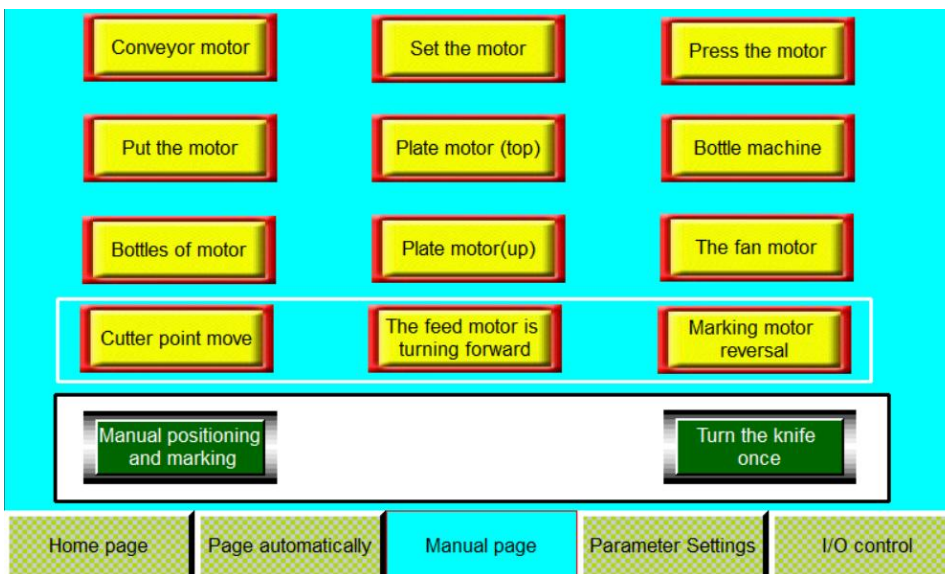

(manual: click the button to drive the motor; release the motor to stop)

**输送电机**: 输送电机电机手动电机, 整台机器的输送带带动电机。

Transmission motor: the manual motor, the transmission motor, the conveyor belt of the whole machine drives the motor.

**套标电机**: 套标电机手动点动电机, 把标签套进样品的主要电机之一。

Marking machine: marking machine manual motor, the label into one of the main motor samples.

**压标电机**: 压标电机手动点动电机, 没有把标签完全套进样品时, 开启压标电机会将标签完全压到样品内。

Mark motor: mark motor manual point motor, when the label is not fully inserted into the sample, open the mark electric machine to completely press the label into the sample.

**放标电机**: 放标电机手动点动电机, 自动运行时, 放标签的电机。

Standard setting motor: manual marking motor, automatic running, label setting motor.

**分瓶电机**: 分瓶电机手动点动电机, 控制进瓶距离, 为防止样品间距过小, 导致电眼检测失误。

Flask motor: the manual point motor of the flask motor controls the distance to the bottle. In order to prevent the sample spacing from being too small, the electric eye detection error is caused.

**导瓶电机**: 导瓶电机手动点动电机。

Guide cylinder motor: guide cylinder motor manual point motor.

**风机电机**: 增加预收缩时, 需要开启的电机。(手动点击功能按键置位, 再次点击复位)

Fan motor: the motor that needs to be turned on when the pre-contraction is increased. (click the function button manually and reset again)

**标板电机上/下**: 根据样品高度手动调整标版电机高度。

Upper/lower plate motor: manually adjust the height of plate motor according to sample height.

**割刀点动**: 割刀电机手动点动电机。

Cutter point: cutter motor manual point motor.

**送标伺服正/反转**: 为第一次穿标签时，手动点动使用。

Mark sending servo forward/reverse: it is used for manual clicking when the label is first put on.

**手动定位送标**: 手动送标，为更换产品或者标签时，需要手动试验标签的稳定性。

Manual positioning and marking: manual marking, in order to replace products or labels, manual testing of label stability.

**割刀转一圈/回原点**须把割刀回到原点，否则自动机器一直处于待机状态。

The cutter must return the cutter to the original point after a turn/return to the original point, otherwise the automatic machine is always in standby.

### 3, 参数设置

割刀自动速度	<input type="text" value="888888"/> PPS <a href="#">帮助</a>	送标自动速度	<input type="text" value="888888"/> PPS <a href="#">帮助</a>
割刀手动速度	<input type="text" value="88888"/> PPS <a href="#">帮助</a>	送标手动速度	<input type="text" value="88888"/> PPS <a href="#">帮助</a>
放标延时启动	<input type="text" value="8.888"/> S <a href="#">帮助</a>	延时停标	<input type="text" value="8.888"/> S
放标延时停止	<input type="text" value="8.888"/> S <a href="#">帮助</a>		
标签长度	<input type="text" value="8888"/> mm <a href="#">帮助</a>		

首页 | 自动页面 | 手动页面 | **参数设置** | I/O监控

### 3. Parameter setting

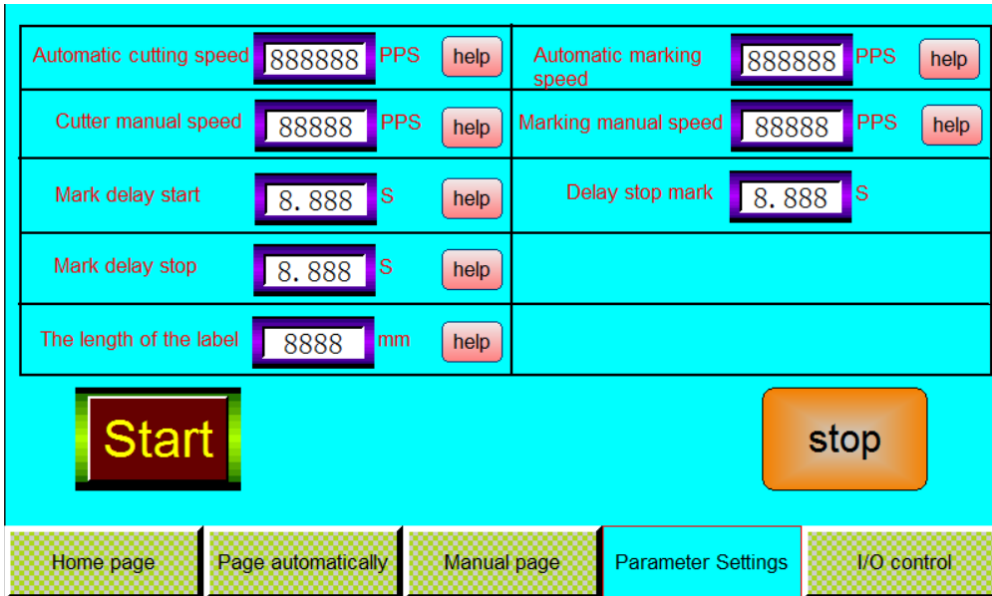

割刀自动速度：割刀电机自动运行的速度。

Automatic cutting speed: the speed of automatic operation of cutter motor.

割刀手动速度：割刀电机手动运行的速度。

Cutter manual speed: cutter motor manual operation speed.

放标延时启动：放标签启动前延时的时间

Label delay start: the delay time before label start

放标延时停止：放标签停止前延时的时间。

Label delay stop: the delay time before the label stop.

标签长度：设置标签需要的长度。（在标签长度模式中可用）

Label length: sets the length required for the label. (available in TAB length mode)

送标自动速度：送标电机自动运行的速度。

Automatic speed of bid delivery: the speed of automatic operation of bid

delivery motor.

送标手动速度：送标电机手动运行的速度。

Manual speed of bid delivery: the speed of manual operation of bid delivery motor.

延时停标：：出标设置好的标签长度之后，再进行的延时设置

Delay stop: the delay setting shall be carried out after the label length is set

#### 4, I/O 监控



I/O 监控： 监控各个功能元件的运转情况，运转的元件涂红表示相应的功能元件在工作，方便用于故障检修。

**I/O monitoring: monitor the operation of each functional element. The red color of the operating element indicates that the corresponding functional element is working, which is convenient for troubleshooting.**



### 9-3 常见异常与解除：

### 9-3 common exceptions and rescission:

触摸屏状态显示	原因	排除方法
送标异常	送标伺服超载或卷标卡料	按下 <b>急停</b> 键，排除异常后从新开机。
刀盘异常	刀盘伺服超载或卷标卡料	同上。
标签缺料	无料带或供料轮未压紧	更换料带，检查供料滚轮张开夹是否关闭。
紧急停止	紧急停止按钮 OFF	将紧急按钮 ON

<b>Touch screen status display</b>	<b>reason</b>	<b>Elimination method</b>
Send the abnormal	Marking servo overload or marking material	Press the emergency stop button to restart the machine after removing the abnormality.
The knife dish abnormal	Tool plate servo overload or marking material	Same as above.
The label is short of material	No tape or feed wheel is not compressed	For the replacement tape, check whether the opening clamp of the feed roller is closed.
Emergency stop	The emergency stop button is OFF	Push the emergency button ON

切刀不能归原点：检查原点感应器是否损坏

The cutter cannot return to the original point: check the origin sensor for damage

**The knife dish motor**

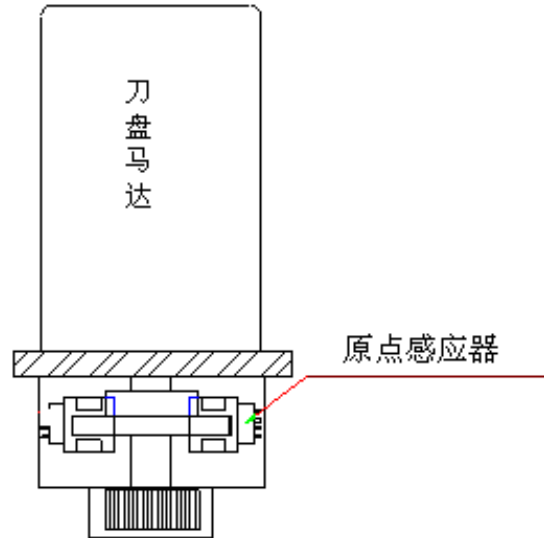

**Origin sensor**

其它组件的调整（选用配

件部份）

## Chapter 10 adjustment of other components

10-1 规格表：

型 号	PM-100B	PM-200B	PM-300B	PM-400B
主机尺寸	2100L*850W*2000H	2100L*850W*2000H	2100L*1100W*2200H	2500L*1200W*2200H
生产速度	100B~200B	200B~300B	300B~400B	400B~500B
主机使用电源	1Ø/220V、3Ø/220V	1Ø/220V、3Ø/220V	1Ø/220V、3Ø/220V	1Ø/220V、3Ø/220V
主机功率	2KW	2KW	2KW	6KW
主机框架材质	不锈钢	不锈钢	不锈钢	不锈钢
标签长度	30mm~260mm	30mm~260mm	30mm~180mm	30mm~180mm
标签厚度	0.03mm~0.13mm	0.03mm~0.13mm	0.03mm~0.13mm	0.03mm~0.13mm
瓶罐直径	28mm~125mm	28mm~125mm	28mm~125mm	28mm~125mm
瓶罐高度	50mm~280mm	50mm~280mm	50mm~280mm	50mm~280mm
瓶罐形状	方、圆、椭圆、扁瓶	方、圆、椭圆、扁瓶	方、圆、椭圆、扁瓶	方、圆、椭圆、扁瓶
收缩炉功率	13~15KW(或蒸汽)	13~15KW(或蒸汽)	13~15KW(或蒸汽)	13~15KW(或蒸汽)

Specification table:

model	PM-100B	PM-200B	PM-300B	PM-400B
Size of the host	2100L*850W*2000H	2100L*850W*2000H	2100L*1100W*2200H	2500L*1200W*2200H
Production speed	100B~200B	200B~300B	300B~400B	400B~500B
Main engine power supply	1Ø/220V、 3Ø/220V	1Ø/220V、 3Ø/220V	1Ø/220V、 3Ø/220V	1Ø/220V、 3Ø/220V
The host power	2KW	2KW	2KW	6KW
Host frame material	Stainless steel	Stainless steel	Stainless steel	Stainless steel
The length of the label	30mm~260mm	30mm~260mm	30mm~180mm	30mm~180mm
The thickness of the label	0.03mm~0.13mm	0.03mm~0.13mm	0.03mm~0.13mm	0.03mm~0.13mm
Bottles diameter	28mm~125mm	28mm~125mm	28mm~125mm	28mm~125mm
Container is highly	50mm~280mm	50mm~280mm	50mm~280mm	50mm~280mm
Shape of bottles	Square, round, oval, flat bottle	Square, round, oval, flat bottle	Square, round, oval, flat bottle	Square, round, oval, flat bottle
Shrinkage furnace power	13~15KW (Or steam)	13~15KW (Or steam)	13~15KW (Or steam)	13~15KW (Or steam)

10-2 带瓶组、分瓶螺杆、刷下组、预收缩炉等组件调整，为应配合各种不同瓶形生产时必须适合该瓶形条件而重新调整设定。

10-2 adjustment of components including bottle group, bottle screw, brush down group, pre-shrinkage furnace, etc., to adjust the setting again to meet the requirements of different bottle shape production.

10-3 上述调整练习请操作人员配合本公司工程人员于交机时段，操作教育训练时多练习。

10-3 the above adjustment exercises shall be carried out by the operator in cooperation with the engineering personnel of the company during the handover period.

## 第十一章 润滑与保养

### Chapter xi lubrication and maintenance

#### 11-1 每日例行检点事项

#### 11-1 daily routine inspection items

11-1-1 导杆、导轨、螺杆、滑座、轴承等滑动面，请每两周上一次润滑油，可使用国内品牌特级循环机油 R32，或相当等级 VG32 牌润滑油。

11-1-1 guide rod, guide rail, screw rod, slide seat, bearing and other sliding surfaces should be lubricated once every two weeks. Domestic brand special circulating machine oil

*R32 or equivalent grade VG32 can be used.*

11-1-2 齿轮每周上一次油，使用一般机用油脂。

*11-1-2 gear oil once a week, using general machine grease.*

11-1-3 上油之前请先以干净的软布去除原有旧油。

*11-1-3 applying oil, please remove the old oil with a clean soft cloth.*

11-1-4 润滑点若有明显异物污染，比如灰尘、铁屑、水份等，应立即做清理再上润滑油。

*11-1-4 if there is any obvious foreign matter pollution at the lubrication point, such as dust, iron scrap, water, etc., clean up immediately and add lubricating oil.*

11-1-5 其他机件在平时点检有发现生锈及锈斑，应立即处理做除锈与上油。

*The rust and rust spots of other machine parts in the 11-1-5 phase were found in the spot inspection at ordinary times. The rust and oil should be removed immediately.*

11-1-6 机台部份请维持其表面清洁度，避免将不相干物品置放于机台上。

*11-1-6 please keep the surface clean to avoid placing irrelevant items on the platform.*

11-1-7 每周应检查各传动部位皮带是否有断裂或严重破损，本项请预购备品待更换。

*11-1-7 every week, check whether the belt of each drive part is broken or seriously damaged. Please purchase the spare parts in advance for replacement.*

11-1-8 请制作相关的保养表格，按时保养。

*11-1-8 please make the relevant maintenance form and maintain it on time.*

11-1-9 电器盘每周用空气枪清除灰尘或物，确保电器零件正常运作。

*11-1-9 dust or objects shall be removed by air gun every week to ensure the normal operation of electrical parts.*

11-1-10 开机前必须确认刀片与中心柱环沟相对位置与刀片原点。

*11-1-10 before starting up, the relative position of blade and center column ring groove and blade origin must be confirmed.*

11-1-11 开面前确认中心柱两侧驱动轮位置是否正确，驱动轮是否固锁住，以免中心柱依移。

*Before opening, confirm whether the driving wheel position on both sides of the center column is correct, and whether the driving wheel is locked firmly to avoid the center column moving.*

11-1-12 确认刷下轮是否与中心柱下段的滚轮中心高一致，并轻压于滚轮上。

*11-1-12 confirm whether the brush down wheel is in line with the height of the roller center in the lower section of the central column, and press lightly on the roller.*

11-1-13 确认输送带上面是否有异物滞留。

*11-1-13 confirm whether there is any foreign matter on the conveyor belt.*

11-1-14 确认料架上标签膜料穿料、位置是否正常，膜料有无变形。

*11-1-14 confirm whether the label film material on the material rack is in normal position and deformation.*

11-1-15 确认料架上收缩膜料中心是否与中心柱中心对齐，否则应调整料盘位置。

*11-1-15 confirm whether the shrinkage film material center of the material rack is aligned with the center of the central column, otherwise the position of the material plate*

*should be adjusted.*

11-1-16 确认主机刀盘座高度位置，是否为该瓶子的生产条件。

*11-1-16 confirm the height of the cutter holder of the host machine, whether it is the production condition of the bottle.*

11-1-17 确认带瓶组的定位皮带位置，与夹持瓶子的压力不宜太紧。

*11-1-17 confirm the positioning belt position of the bottle holder, and the pressure of the bottle holder should not be too tight.*

11-1-18 确认热收缩炉组的旋转皮带，与夹持瓶子的压力不宜太紧。

*11-1-18 confirm that the rotating belt of the heat-shrinkable furnace group should not be too tight with the pressure of holding the bottle.*

11-1-19 确认带瓶组的夹瓶子中心，是否位于中心正下方。

*11-1-19 confirm whether the bottle holder center with the bottle holder group is located directly below the center.*

11-1-20 确认带瓶组皮夹持瓶子后所移动速度，与输送带速度是否同步。11-1-20 confirm whether the movement speed of the bottle holder with the bottle holder is in sync with the conveyor belt speed.

11-1-21 确认照瓶电眼位置是否正确，请于生产前先行测试套标签。

*11-1-21 confirm whether the electric eye position of the lighting bottle is correct, please test the cover label before production.*

11-1-22 作业完毕，请先关闭收缩炉的开关，保持风扇冷却约十分钟后，再关闭风扇开关及电源开关。

*11-1-22 when the operation is finished, please turn off the switch of the retractor firstly, keep the fan cool for about 10 minutes, and then turn off the fan and the power game.*

11-1-23 最后请依照人机介面操控说明内的关机步骤作业，请关闭主电源。分瓶螺杆连瓶时瓶身是否在中心柱下方正中心截止。

*11-1-23 finally, please follow the shutdown procedure in the manual of human-computer interface control. Please turn off the main power. When separating screw is connected with bottle, whether the bottle body is cut off in the center under the center column.*